

NOTES

(C) THIS DRAWING IS COPYRIGHT
 CONTRACTORS MUST CHECK ALL DIMENSIONS ON SITE. ONLY FIGURED DIMENSIONS ARE TO BE WORKED FROM. DISCREPANCIES MUST BE REPORTED IMMEDIATELY TO JUBB CONSULTING ENGINEERS LIMITED BEFORE PROCEEDING.
 THIS DRAWING MUST BE READ IN CONJUNCTION WITH THE CURRENT ENGINEERING SPECIFICATIONS AND RISK ASSESSMENTS.
 ALWAYS CHECK FOR LATER REVISIONS OF THIS DRAWING.

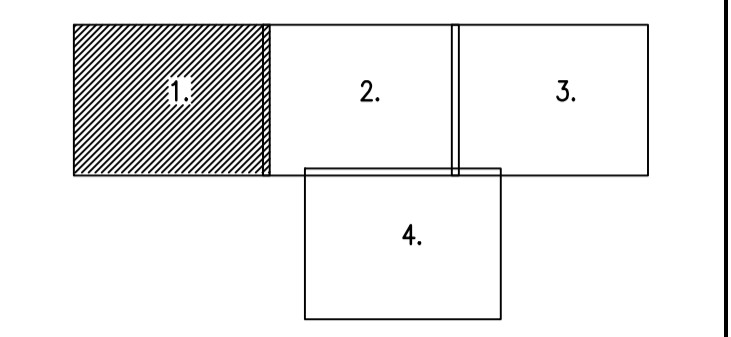

REV	DATE	DESCRIPTION	DR	N	CH	K	APP'D	ENG	
M	16:07:12	CONSTRUCTION ISSUE					S.H	T.A	T.A
L	20:06:12	Existing services added to layout, foul & surface water drainage amended to suit.					S.H		
K	05:04:12	Existing vehicular access proposals amended to suit comments.					S.H		
J	02:04:12	Carriageway amended to suit existing vehicular access.					S.H		
H	28:02:12	Add & Omits.					S.H		
G	23:02:12	Contours amended to suit existing vehicular access.					S.H		
F	20:12:11	Amended to suit SWW technical comments of 09/12/11.					S.H		
E	01:12:11	Soakaway resized and relocated, foul sewer moved to suit. Layout amended to suit Windes coals.					S.H		
D	22:11:11	TENDER ISSUE					S.H		
C	21:11:11	Foul drainage & Soakaway amended.					S.H		
B	18:11:11	Various changes as required.					S.H		
A	28:10:11	Layout supersedes H102-H104 series.					S.H		

Issue Status	CONCEPT	CONSTRUCTION
<input type="checkbox"/>	<input type="checkbox"/>	<input type="checkbox"/>
<input type="checkbox"/>	<input type="checkbox"/>	<input type="checkbox"/>
<input type="checkbox"/>	<input type="checkbox"/>	<input type="checkbox"/>
<input type="checkbox"/>	<input type="checkbox"/>	<input type="checkbox"/>

Project
BRIXHAM ROAD PAIGNTON

Detail
REGRADE & DRAINAGE LAYOUT SHEET 1 OF 4

Client/Architect
**CAVANNA HOMES (SW LTD)
 PARKBAY DEVELOPMENTS LTD**

Scale @ A1
1:200

Project Ref P9464	Drawing No H125	Rev M
-----------------------------	---------------------------	-----------------

JUBB
 CONSULTING ENGINEERS LIMITED

CIVIL STRUCTURAL ENVIRONMENTAL
 TRAFFIC HIGHWAYS GEOTECHNICAL

BRISTOL: TEL 0117 922 6266, FAX 0117 922 6813, E.MAIL: BRISTOL@JUBB.CO.UK

FARNBOROUGH: TEL 01252 551000, FAX 01252 551025, E.MAIL: FARNBOROUGH@JUBB.CO.UK

CARDIFF: TEL 02920 524444, FAX 02920 524445, E.MAIL: CARDIFF@JUBB.CO.UK

PLYMOUTH: TEL 01752 797000, FAX 01752 797001, E.MAIL: PLYMOUTH@JUBB.CO.UK

NOTES:

- To be read in conjunction with Engineer's current drainage construction details P9464/H123 and specification document H120.
- All levels are related to Ordnance Survey.
- The planning, design and construction of sewers shall be carried out in accordance with 'Sewers for Adoption' 6th Edition, a design and construction guide for developers, the Civil Engineering Specification for the Water Industry 6th edition and South West Water amendments to CESWI dated may 1999.
- The minimum size of sewer where guide bars, safety chains, or other safety devices are required in manholes shall be 375mm in diameter.
- All type A, B and E manholes should have a concrete surround. Concrete rings shall be sealed using 'Tokstrip' and lifting eyes pointed with resin modified mortar.
- Compliance with Health and Safety matters on any trench/manhole is obligatory and a permit to enter a confined space is required when connecting site drainage to existing public sewerage system. A permit to enter a confined space will be obtained from SWW Ltd prior to the works commencing on any public sewerage system. Contractor to provide Method Statement and approval prior to the works commencing on any public sewerage system.
- Manhole covers and frames shall be ductile iron with a minimum square opening of 675x675mm. Covers shall be double triangle for 675mm square openings and be provided with loose bolted connections. All manhole frames shall typically be 150mm deep but in all cases shall comply with CESWI cl 5.2.32 & Table 5.7 (SFA6 page 124). The manhole frames shall be bedded on resin modified mortar.
- Manhole covers shall be marked FW for foul water manholes and SW for surface water manholes.
- The use of ladders or steps in manholes, wet wells and valve chambers shall comply with the following: Steel plastic encapsulated MH single steps shall not be used in manholes of a greater depth than 1m. Steel plastic encapsulated double steps (polypropylene encapsulated type to comply with wis 4-33-01) may be provided in manholes up to 3m in depth. Ladders shall be provided in accordance with BS 4211 in MHS between 3.0m & 6.0m deep. MHS greater than 6.0m deep shall be specially designed and have intermediate landings. Access holes in intermediate landings shall be provided with galvanized mild steel gratings to prevent persons falling through. The design of deep manholes shall permit the use of a winch or lifting gear mounted at ground level in case of emergencies.
- Only low carbon steel or stainless steel ladders for vertical fixing to manholes will be acceptable.

- Proposed adoptable sewers are only permitted to have other sewer/gully connections and other services laid at an angle of between 45 degrees and 90 degrees across the line with a vertical clearance in excess of 300mm.
- All ironwork to be kite marked by BSI or certified by equal inspection authority.
- Red coloured plastic marker tape at least 150mm wide shall be laid at a minimum of 200mm above the soffit of pipe. The tape shall be printed with the words 'GRAVITY SEWER' in bold capital letters throughout its length and at intervals not exceeding 700mm and shall incorporate a corrosion resistant tracing system for non metallic pipes.
- Backdrops shall be a minimum of 1.0m in height. Maximum 1.5m above benching.

NOTES:

- SURVEY RELATED TO OSGB36. REFERENCE POINT TAKEN ON WALL ALONG BRIXHAM ROAD LEVEL 75.07m AOD. (WALL NO LONGER IN EXISTANCE) COORDS OF DATUM POINT: 287555.548E 58849.081N
- EXACT POSITION OF SERVICES ALONG PROPOSED DRAINAGE ROUTES TO BE DETERMINED BEFORE EXCAVATION WORKS COMMENCE.

SEE BELOW FOR CONTINUATION

CONTINUATION